

NOAA Technical Report, OAR-AOML-50

<https://doi.org/10.25923/ffz6-0x48>



Installation of Autonomous Underway $p\text{CO}_2$ Instruments onboard Ships of Opportunity

D. Pierrot
T. Steinhoff

Atlantic Oceanographic and Meteorological Laboratory
Miami, Florida

April 2019

U.S. DEPARTMENT OF
COMMERCE

noaa

NATIONAL OCEANIC AND ATMOSPHERIC ADMINISTRATION
OFFICE OF OCEANIC AND ATMOSPHERIC RESEARCH

Suggested Citation

Pierrot, D., and T. Steinhoff, 2019: Installation of autonomous underway $p\text{CO}_2$ instruments onboard ships of opportunity. NOAA Technical Report, OAR-AOML-50 (doi:10.25923/ffz6-0x48), 31 pp.

Acknowledgments

Denis Pierrot acknowledges the support of the Cooperative Institute for Marine and Atmospheric Studies (CIMAS), a cooperative institute of the University of Miami and the National Oceanic and Atmospheric Administration, cooperative agreement No. NA10OAR4320143, as well as the NOAA Global Ocean Monitoring and Observing (GOMO) Division.

Disclaimer

NOAA does not approve, recommend, or endorse any proprietary product or material mentioned in this document. No reference shall be made to NOAA or to this document in any advertising or sales promotion which would indicate or imply that NOAA approves, recommends, or endorses any proprietary product or proprietary material herein or which has as its purpose any intent to cause directly or indirectly the advertised product to be used or purchased because of this document. The findings and conclusions in this report are those of the authors and do not necessarily represent the views of the funding agency.

NOAA Technical Report, OAR-AOML-50

<https://doi.org/10.25923/ffz6-0x48>

Installation of Autonomous Underway $p\text{CO}_2$ Instruments onboard Ships of Opportunity

Denis Pierrot^{1,2}
Tobias Steinhoff³

¹NOAA–Atlantic Oceanographic and Meteorological Laboratory
Miami, Florida

²University of Miami-Cooperative Institute for Marine and Atmospheric Studies
Miami, Florida

³GEOMAR Helmholtz Centre for Ocean Research
Kiel, Germany

April 2019

UNITED STATES DEPARTMENT OF COMMERCE

Mr. Wilbur L. Ross, Jr., Secretary

NATIONAL OCEANIC AND ATMOSPHERIC ADMINISTRATION

Dr. Neil Jacobs, Under Secretary for Oceans and Atmosphere and NOAA Administrator (Acting)

OFFICE OF OCEANIC AND ATMOSPHERIC RESEARCH

Mr. Craig N. McLean, Assistant Administrator



Key Contributors

Charles Roman Battisti, Tor de Lange, and Sigve Naustdal

Geophysical Institute, University of Bergen, Bergen, Norway

ICOS Ocean Thematic Center, University of Bergen, Bergen, Norway

Kevin Sullivan

Cooperative Institute for Marine and Atmospheric Studies/Rosenstiel School of

Marine and Atmospheric Science, University of Miami, Miami, Florida USA

Rik Wanninkhof

National Oceanic and Atmospheric Administration/Atlantic Oceanographic and

Meteorological Laboratory, Miami, Florida USA

Table of Contents

Figures	iii
Tables	iii
Acronyms	v
Abstract	vii
1. Introduction	1
2. Hardware Requirements	2
2.1 Mandatory Hardware.....	2
2.1.1 System and analyzer	2
2.1.2 Standards	2
2.1.3 Sea surface temperature sensor	3
2.1.4 Global Positioning System and atmospheric pressure transducer	3
2.1.5 Tygon or stainless steel tubing for seawater	3
2.1.6 Air line	3
2.1.7 Water line.....	4
2.2 Auxiliary Hardware.....	4
2.2.1 Thermosalinograph sensor.....	4
2.2.2 Drain tank and pump (if system is below water line).....	5
2.2.3 Antifouling device and cleaning seawater intake lines.....	5
2.2.4 Safety valve	6
2.2.5 Seawater pump (if ship pressure is insufficient)	6
2.2.6 Tubing for freshwater.....	7
2.3 Hardware Suggestions.....	7
3. Preparing for Installation	8
3.1. Choosing a Location for Components	8
3.1.1 Find a space to mount the system	8
3.1.2 Locate access to seawater source	8
3.1.3 Locate power source and voltage for system.....	8
3.1.4 Find a location for the deck box.....	9
3.1.5 Find a location for the atmospheric air intake	9
3.2 Preparing the Ship and System	9
3.2.1 Ship modifications.....	9
3.2.1.1 Strut channels/racks.....	9
3.2.1.2 Power	10
3.2.1.3 Water intake and outlet	10
3.2.1.4 Freshwater intake valve	10
3.2.2 System	10
3.2.2.1 Deck box signal and power cables/air line.....	10
3.2.2.2 Drain tank customization for installation.....	11

Table of Contents (continued)

4. Installing the System.....	12
4.1. Main Components.....	12
4.1.1 System (space considerations, relative positioning of components)	12
4.1.2 Drain tank and pump.....	12
4.1.3 Seawater/freshwater lines and inline sea surface temperature sensor.....	13
4.1.4 Standard gas cylinders and connecting tubing.....	14
4.2 Peripherals.....	15
4.2.1 Air inlet.....	15
4.2.2 Deck box.....	15
4.2.3 Cables/air line	15
5. Testing the Installation	16
5.1 Standard Gas Leaks	16
5.2 Communication with Peripherals	16
5.3 System Gas Leaks.....	16
5.4 Water Tightness of System	16
5.5 Evacuation of Seawater Drain (water tightness, timing).....	17
5.6 Emergency Shutoff	17
6. Potential Issues	17
6.1 Ground Issues on Ships	17
6.2 Recirculating Seawater.....	17
6.3 Miscellaneous Problems	17
7. References.....	18

Figures

1. Schematic overview of the full installation of an autonomous underway $p\text{CO}_2$ system.....	1
2. Steps in the installation process.....	2
3. Example of a drain pump.....	5
4. Schematic of a copper anode-based antifouling device.....	6
5. Example of a pneumatic ball valve	7
6. Example of an air line termination kit.....	9
7. Example of strut channel specifications	10
8. General Oceanics system mounted on a custom built steel frame.	10
9. Illustration of a ball valve	11
10. Illustration of a magnetic float switch	11
12. Setup diagram of drain tanks.....	12
12. Drain tank and pump installed on a ship.....	12
13. Extra syphon break in drain hose	13
14. Drain tank setup to facilitate priming the pump	14
15. Best location for the freshwater supply	14
16. Example of the NOAA/AOML deck box design (contact authors for details)	16
17. Illustration of a syphon break.....	17

Tables

1. Examples of hardware commonly used with the General Oceanics system	8
--	---

This page intentionally left blank.

Acronyms

CO ₂	Carbon dioxide
fCO ₂	Fugacity of carbon dioxide
GPS	Global positioning system
pCO ₂	Partial pressure of carbon dioxide
O ₂	Oxygen
SST	Sea surface temperature
TSG	Thermosalinograph
WMO	World Meteorological Organization

This page intentionally left blank.

Abstract

The oceans are the largest sustained sink of anthropogenic carbon with a flux into the ocean of about $2.4 \cdot 10^{15}$ grams, or 2.4 gigatons, of carbon annually, thereby partially mitigating the rapid increase of this climate-forcing gas into the atmosphere. To provide meaningful projections of future atmospheric CO_2 levels and surface oceanic CO_2 concentrations, we must constrain the flux of CO_2 across the air-water interface. An important component of this effort is to obtain more systematic observations of CO_2 in the ocean by installing autonomous systems—underway $p\text{CO}_2$ analyzers—on ships of opportunity. The purpose of this technical report is to provide the necessary information required to perform such an installation. The information it contains pertains specifically to the installation of the system built by General Oceanics, Inc. in Miami, Florida. However, most of the instructions and issues discussed should apply to any type of autonomous system.

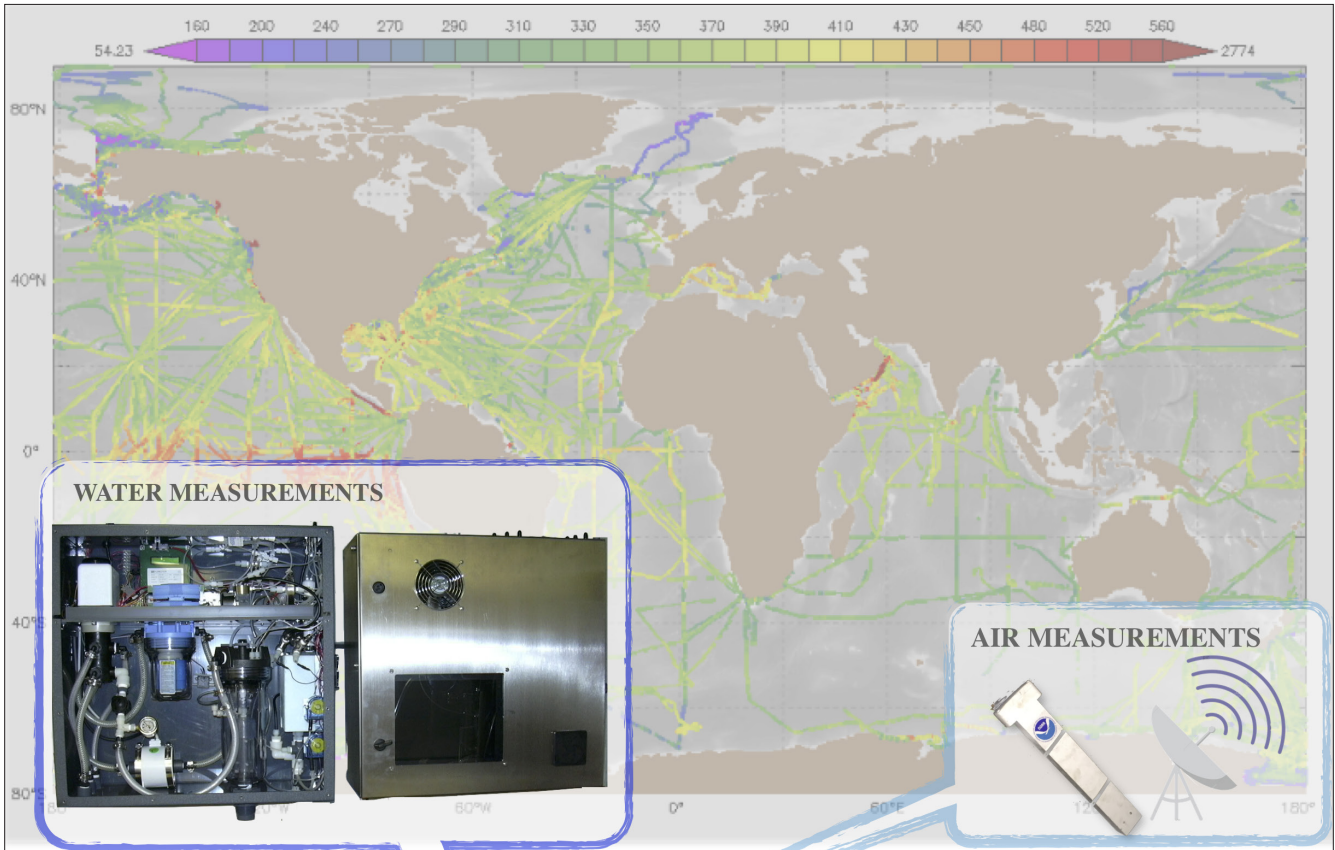

Ice-core data before 1958. Mauna Loa data after 1958.

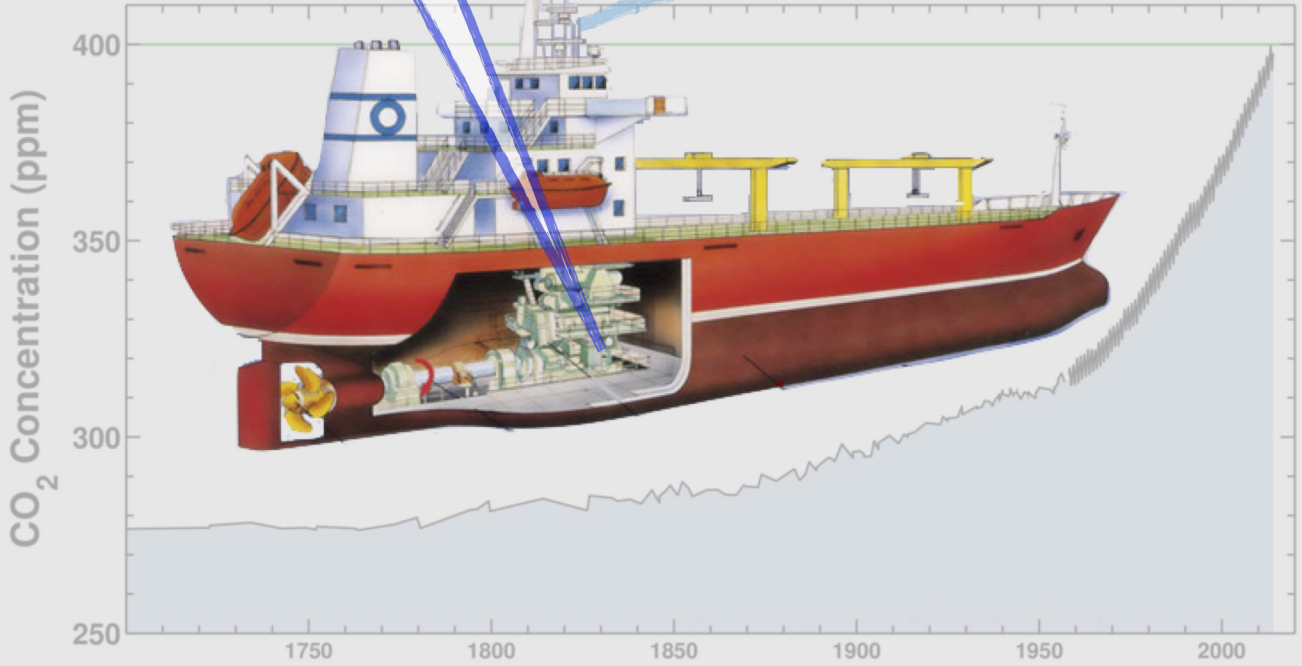

1. Introduction

The oceans are the largest sustained sink of anthropogenic carbon with a flux into the ocean of about 2.4×10^{15} grams, or 2.4 gigatons, of carbon annually, thereby partially mitigating the rapid increase of this climate-forcing gas into the atmosphere. To provide meaningful projections of future atmospheric carbon dioxide (CO_2) levels and surface oceanic CO_2 concentrations, we must constrain the flux of CO_2 across the air-water interface. An important component of this effort is to obtain more systematic observations of CO_2 in the ocean by installing autonomous systems—underway $p\text{CO}_2$ [partial pressure of CO_2] analyzers—on ships via the Ship of Opportunity Program, a part of the Joint Technical Commission for Oceanography and Marine Meteorology’s Ship Observation Team. The purpose of this technical report is to provide the necessary information required to perform such an installation.

There are a number of fairly new companies that sell $p\text{CO}_2$ measuring devices, each using different technologies and reporting different accuracies. The information presented herein pertains specifically to the installation of the system built by General Oceanics, Inc. in Miami, Florida. This system is the result of a community effort where several

$p\text{CO}_2$ experts collaborated to design what was thought as the best instrument to perform reliable and accurate autonomous underway $p\text{CO}_2$ measurements onboard ships of opportunity. To date, it is regarded as the “gold standard” to which other systems are compared. However, most of the instructions and issues discussed should apply to any type of autonomous system. A schematic overview of an underway $p\text{CO}_2$ system installation is shown in **Figure 1**.

This document is organized into different sections that correspond to the different phases of an installation. The first phase is the hardware requirements, which consists of making sure all the necessary gear to perform a successful installation is available. The second phase is the preparation phase, where one scopes the ship for adequate space and possible modifications necessary for the installation. The third phase is the installation itself, with all of the possible issues that need to be taken into account. The last phase involves testing the system to ensure it performs properly. The reader is advised to start at the Table of Contents to find the section related to the appropriate phase of the installation (**Figure 2**). For instructions on the best sampling and data processing procedures, see Pierrot *et al.* (2009).

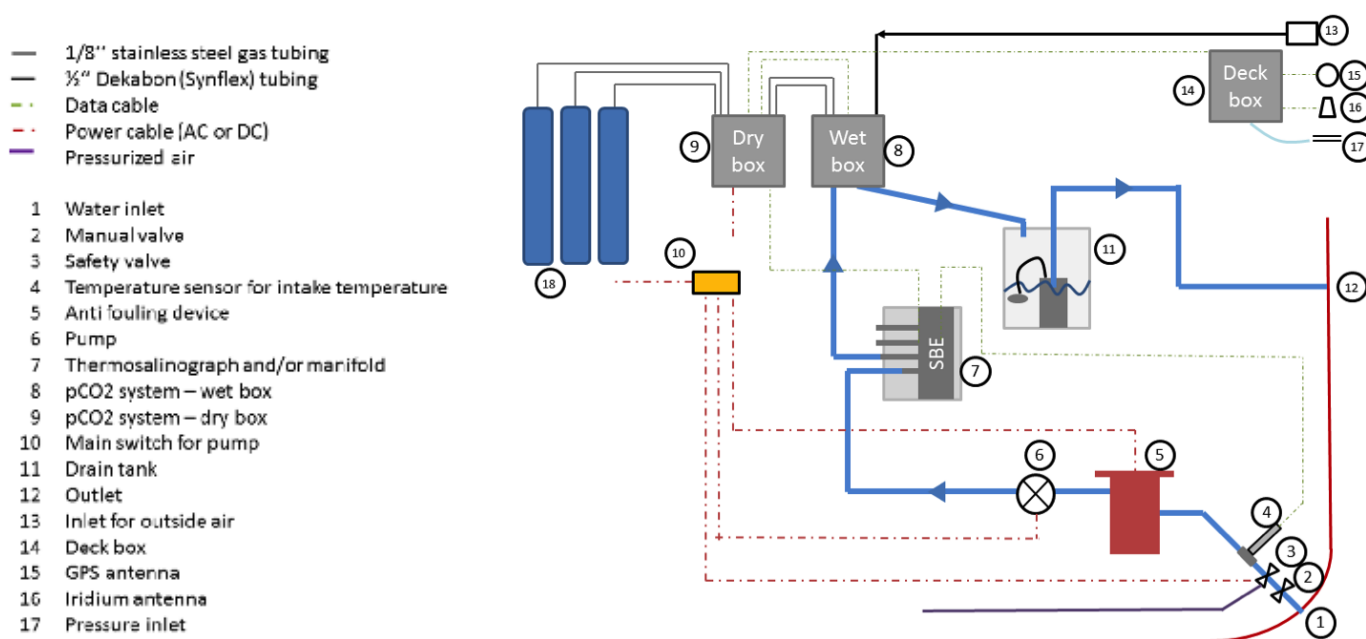

Figure 1. Schematic overview of the full installation of an autonomous underway $p\text{CO}_2$ system.

2. Hardware Requirements

The General Oceanics system was developed to provide the scientific community with a commercial system for constraining regional fluxes of the carbon cycle to $0.2 \text{ Pg C year}^{-1}$, as recommended by Bender *et al.* (2002). This corresponds to measuring the fugacity of CO_2 ($f\text{CO}_2$) of the atmosphere with an accuracy of $0.2 \text{ } \mu\text{atm}$ and of seawater with an accuracy of $2 \text{ } \mu\text{atm}$. To achieve these values, a number of conditions have to be met which are described in section 2.1 (Mandatory Hardware). A number of optional features described in section 2.2 (Auxiliary Hardware) are also given with the purpose of either supplementing the ship's infrastructure or facilitating maintenance of the system.

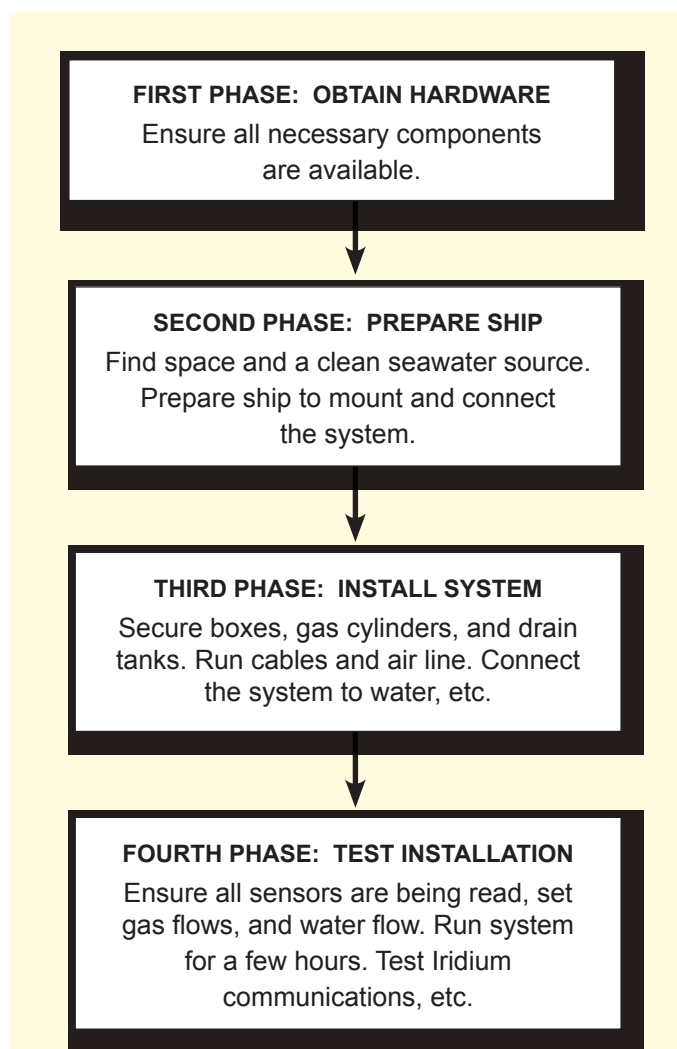

Figure 2. Steps in the installation process.

2.1 Mandatory Hardware

2.1.1 System and Analyzer

To produce the best quality data, the measuring system must meet the following criteria (Wanninkhof *et al.*, 2013):

- The quantity measured should be the dry mole fraction of CO_2 .
- The process used should be based on an air-water equilibrator design with air and water in direct contact.
- The mole fraction should be measured by infrared absorption or gas chromatography.¹
- The accuracy of the temperature measurement from the equilibration process should be $\pm 0.05^\circ\text{C}$.²
- The accuracy of the pressure measurement from the equilibration process should be $\pm 2 \text{ hPa (mbar)}$.²
- The intake seawater temperature should be measured with an accuracy of $\pm 0.05^\circ\text{C}$.²
- At least two non-zero standards traceable to the World Meteorological Organization (WMO) should be used in the calibration of the analyzer.
- The sample gas stream being measured should be partially dried before reaching the analyzer to minimize water interference.

2.1.2 Standards

At least two non-zero gas standards traceable to the WMO CO_2 scale are necessary to generate accurate data. However, using three or four non-zero gas standards is highly recommended so that the range of concentrations expected to be measured can be bracketed and well represented by the concentrations of the standards. Ideally, the standards will include a zero gas, a reference gas with a concentration close to that of the sampled seawater, two reference gases bracketing the atmospheric

¹Interferometer-based instruments (e.g., Picarro, Los Gatos) have been shown to have superior accuracy and stability and could also be used, but they are significantly more expensive.

²Temperature and pressure accuracy criteria for good data have been slightly revised from Pierrot *et al.* (2009) so as to include alternate sensors (see Wanninkhof *et al.*, 2013).

concentration ($\pm 20 \mu\text{atm}$), and a reference gas with a concentration higher than the highest expected $f\text{CO}_2$ of the water measured. The zero gas and highest standards are used as end members to completely bracket all potential measurements to detect any shift of the system within the range of $f\text{CO}_2$ values used.

During typical operations, tall or even medium size tanks can last a few years. The flow rate for the four standards is 50-60 ml/min. This flow rate should be higher if the gas bottles are stored farther away from the instrument. A higher flow rate decreases flushing time. Standards come from pressurized tanks which must be fit with a regulator to reduce the pressure from up to 150 bar down to about 1.0 bar (≈ 15 psi) (Pierrot *et al.*, 2009).

2.1.3 Sea Surface Temperature Sensor

The sea surface temperature (SST) sensor serves two purposes: primarily, it measures seawater temperature at the intake, but it also helps determine the transit time of the seawater, i.e., the time it takes for the seawater to travel from the intake to the equilibrator. This is important for determining the temperature difference (ΔT) between the intake, approximated as the sea surface temperature and the equilibrator. This difference is needed to calculate the $f\text{CO}_2$ of the sea surface temperature. If the transit time is not accounted for, the ΔT used in the correction will be incorrect. Furthermore, the difference between the equilibrator temperature and the SST should be minimized. The temperature dependence of $f\text{CO}_2$ is about 4.2 percent per degree with an uncertainty of about 0.2 percent. Thus, a 1°C temperature difference for seawater with a $f\text{CO}_2$ of 400 μatm will amount to a 16.8 μatm correction with an uncertainty of 0.8 μatm . For $\Delta T > 1^\circ\text{C}$, the computed $f\text{CO}_2$ can be off by more than 1 μatm . Minimizing the length of tubing between the equilibrator and the seawater intake is the first step to minimizing ΔT . Other viable options include insulating the tubing to prevent heat exchange and maintaining high flow rates. However, constraints within the ship may make this challenging. The SST should be measured with an accuracy of 0.05°C. A SeaBird Model 38 (i.e., remote temperature probe) is extensively used for this purpose.

2.1.4 Global Positioning System and Atmospheric Pressure Transducer

Most current Global Positioning Systems (GPS) are adequate, with an accuracy of ± 8 m. They should provide the \$GPGGA NMEA string to facilitate incorporation into the underway system data stream. If the GPS date is desired, the GPS should also output the \$GPRMC string. If the underway system measures atmospheric CO₂ concentrations, a pressure transducer is needed to convert these atmospheric xCO₂ measurements to fugacity. The model commonly used for this purpose is a Druck PT350. Atmospheric pressure measurements should be accurate to 0.2 hPa.

2.1.5 Tygon or Stainless Steel Tubing for Seawater

Tubing is necessary to transfer seawater from the inlet, through the CO₂ wet box and external sensors (SST, thermosalinograph [TSG], oxygen [O₂], etc.) to the outlet. If the CO₂ system is mounted below the ship's water line, the wet box needs to drain into a reservoir, which is connected to a pump, and then to the exit. Some ships will not accept reinforced Tygon tubing connected to the inlet and outlet. In these cases, stainless steel tubing should be used. Reinforced Tygon tubing is acceptable between the analytical components located behind the safety valves. The tubing should be sized (minimum 3/8" inner diameter inlet and 1/2" inner diameter outlet) and routed (minimal and gentle bends) so the pumps can easily push seawater through the tubing. Note: anecdotal evidence suggests that freshly installed synthetic tubing gives off CO₂ or other gases that could interfere with measurements. It is recommended to have the tubing "cured" by filling it with seawater for at least a day before measurements commence.

2.1.6 Air Line

The underway system should measure atmospheric CO₂ concentrations from an inlet on the bow mast to minimize contamination from the ship's exhausts. However, it is not always possible to install the inlet at the bow. In these cases, the intake should be positioned far away from the ship's exhausts. In addition, one can install a lower cost weather station (e.g., Airmar Technology) that can sense

the wind direction to help detect contamination during data reduction. To measure outside ambient air, a line needs to be run from the system to a location on the ship where the air will have minimal contamination. A mast at the bow of the ship is the preferred location. If this is not possible, a high location as far as possible from the stack gases and structure of the ship is the second best option.

The run for the air line can easily require several hundred feet of tubing. A common material used for this purpose is 3/8" to 1/2" Synflex[®] (previously Dekabon[®] or Dekor[®] 1300) tubing, which is a metal/plastic composite providing strength and rigidity, as well as chemical inertness. The air line should have a cartridge with a coarse filter or glass wool at the inlet to avoid sea spray from entering the line. The AOML group has noticed lower air values (by 0.5 to 1 ppm) with air lines that were used for several years without inlet cartridges. This is attributed to absorption of CO₂ on carbonates and/or other bases precipitated from sea spray in the air line. As a routine measure, the air line should be replaced on research ships every season. The atmospheric intake should have a flow rate of 0.5-2 L/min (Pierrot *et al.*, 2009) so as to flush the air line as much as possible.

2.1.7 Water Line

The specific location of the instrument intake will depend on the configuration of the ship and the space requirements of the instrument. However, certain considerations should be taken into account. On research ships, the seawater inlet is usually located at the bow of the ship to avoid contamination from the ship's hull or wastewater streams. The inlet is usually at a depth of 4-6 m to avoid breaching the intake. The intake placement usually requires a long pipe run to the underway system, and insulating the pipes to minimize temperature increases is recommended. Alternatively, some research vessels have a moon pool, where a submersible pump can be installed that pumps seawater from approximately 6 m depth directly to the instruments. By using a bypass and a high flow rate, this ensures a minimal temperature increase of the seawater.

For commercial ships, the inlet water for the engine cooling system is typically located on the side (port/starboard) of the vessel toward the vessel's center of mass. This reduces vertical movement of the inlet and prevents the inlet from

breaching the surface during transit. The pressure and flow through the engine cooling system is substantial so the transit time is minimal when one samples from this system. The engine cooling system line should be tapped as close to the intake/sea chest as practical.

It is possible that the shipping company allows a dedicated intake to be installed. This would most likely have to be performed during dry dock, and the ship should recommend the valve to be installed to adhere to strict maritime regulations. If the location of the inlet can be selected, then:

- The inlet should be sufficiently forward of the vessel's wastewater outlet to avoid contamination.
- The inlet should also be sufficiently deep to avoid contamination from bubbles or surfactants due to the ship's wake. On larger vessels, such as cargo ships, a depth of 3-6 m has been sufficient.

Again, a bypass line going straight from the inlet to the outlet could be implemented to reduce temperature changes and increase flushing of the intake line. The supply line for the CO₂ system would then tee off from that bypass line.

2.2 Auxiliary Hardware

2.2.1 Thermosalinograph Sensor

Although salinity does not affect the *f*CO₂ calculations significantly, it is an important measurement to interpret results. The instrumentation for salinity is relatively robust. A Seabird Model 45, for example, is easy to install inline, does not require much flow (less than 1.5 l/min), and can be easily interfaced with a computer so that the data can be merged into the underway CO₂ system program. An additional advantage is that the TSG has an accurate internal thermistor and provides an independent temperature measurement of the water at the location of installation. That is, it can serve as a check for the equilibrator temperature if the TSG is placed next to the underway system or for the intake temperature if the TSG is near the intake. TSGs sometimes offer a remote temperature probe whose data stream is incorporated into the TSG data stream, facilitating incorporation into the

underway CO_2 data files. Alternatively, a Seabird Model 21 TSG can be used. This model is larger than the Seabird 45, but has one water inlet and three outlets so can serve as a manifold to maintain a bypass or feed other instruments.

2.2.2 Drain Tank and Pump (if system is below water line)

If the equilibrator is mounted above the water line, the seawater can drain gravimetrically directly overboard. Of note is that if effluent is drained into the ship's gray or black water (sewage) systems, the ship's systems can be overburdened, as all gray and black water goes into holding tanks that need to be pumped overboard periodically. Since the seawater going through the underway system is not treated in any way, it can and should go directly overboard when practical. On research ships, discharge lines can sometimes be rerouted to go directly overboard.

If the equilibrator is mounted below the water line, the seawater will need to drain into a temporary storage reservoir, which will be emptied via a pump. A typical flow rate through the system is about 4 L/min; therefore, a 50-gallon tank (~200 L) will fill in about 50 minutes. The choice of pump to evacuate that water will depend on numerous factors such as:

- The pressure the pump has to push against to evacuate the water (including head pressure due to the height of the outlet).
- The available space.
- Whether the pump can self-prime.

Sump pumps (or submersible pumps) have been used on some installations. Their big advantage is that they fit in the drain tank (i.e., don't take up extra outside space) and often include a mechanism to detect when to start and stop pumping water. However, they are quite susceptible to grounding issues, which is hard to avoid with this kind of pump, particularly on ships where the electrical ground is very different than on land. The impellers inside the pump can slowly dissolve via electrolysis until they fail. The best way around this issue is to use three-phase power, which is easier to obtain on a ship. However, there are risks associated with submersing high-voltage devices.

If an external pump is preferred, a stainless steel head is highly recommended. A mechanism will also have to be installed in the tank to control the pump. A simple solution involves low-cost magnetic reed switches and a relay control board. It is critical that there be a fail-safe system on the drain tank which will shut off the seawater supply line if the water level in the drain tank is close to overflowing. **Figure 3** shows a ½ HP 1725 rpm motor from Leeson Electric Corporation (part No. C4C17FK5B) coupled to a stainless steel MTH T41P series pump, which has proven very reliable on several installations.

2.2.3 Antifouling Device and Cleaning Seawater Intake Lines

Many commercial vessels nowadays have some kind of antifouling device installed (often called a "Marine Growth Prevention System," or MGPS) on their intakes. Dedicated scientific seawater supply lines on research vessels generally do not have antifouling systems. It is prudent in these situations to flush (or back flush) a fresh water bleach solution through the intake line at least once a year. Particular care should be taken to flush the entire system including all valves, junctions, and bypasses upstream of the $p\text{CO}_2$ system. Commonly, adding 2 liters of commercial household bleach followed by a copious freshwater rinse is effective. As shown in Juranek *et al.* (2010), respiration of organic matter can contaminate (increase) the $p\text{CO}_2$ and decrease the O_2 signal. Depressed

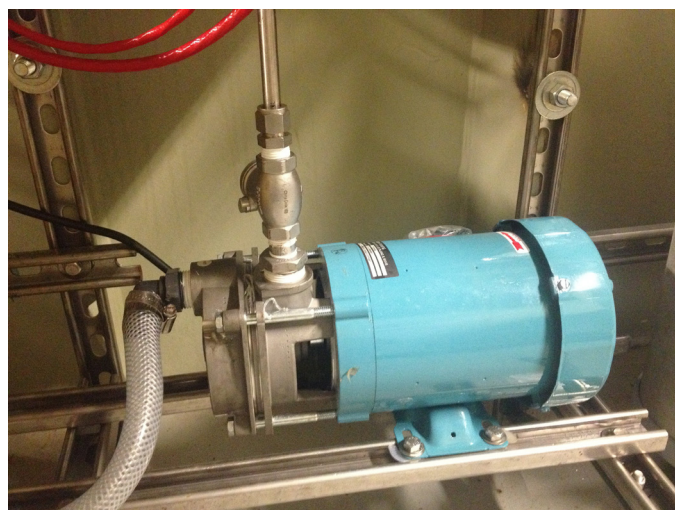

Figure 3. Example of a drain pump.

O_2 levels are often used as an indicator of respiration in the lines. A quick way to determine whether intake line contamination is an issue is to stop the seawater flow for 15-30 minutes, let the water sit in the intake line, and then monitor CO_2 levels in the analyzer upon startup. To avoid false positives, increases in temperature that can elevate CO_2 signals must be taken into account.

It is not recommended to flush the bleach solution through the General Oceanics instrument, as bleach can shorten the life of synthetic parts such as the equilibrator. Flushing the underway system with freshwater, as discussed below, is the most common option to clean the system. If bleach is used, we recommend a dilute solution (10:1) about once a year. Here again, a copious fresh and salt water rinse (at least 10 min each) is required, as bleach is hard to wash off and would affect the $p\text{CO}_2$ readings.

Alternatively, a copper ion-based antifouling system can be installed in the water line (e.g., www.cathelco.com). This copper anode releases copper ions (the amount can be regulated) to poison the seawater. This has no effect on the $p\text{CO}_2$. Figure 4 shows such a strainer solution. The strainer should be positioned right after the intake temperature sensor to prevent fouling in the entire water line.

2.2.4 Safety Valve

On some installations, it might be highly desirable to have the capability of closing the seawater intake programmatically in case of leaks. The General Oceanics system has several liquid sensors, including at the bottom of the wet box and in the outflows of the condenser, where water should not be. A solenoid valve connected to the system can be programmed to close if one of these sensors detects water.

Some ships might request a safety valve that closes automatically when any incident happens on the ship (e.g., power failure). Pneumatic ball valves (Figure 5) have proven themselves in this kind of installation but need pressurized air to work. If the power is on, the pressurized air keeps the valve open. If there is a power failure, the valve closes automatically by mechanical springs inside.

2.2.5 Seawater Pump (if ship pressure is insufficient)

The General Oceanics $p\text{CO}_2$ instrument runs best when the seawater source can deliver at least 4 L/min. If the ship's system cannot deliver a high enough flow and pressure, a booster pump should be used. The pump should be designed for continuous use with performance

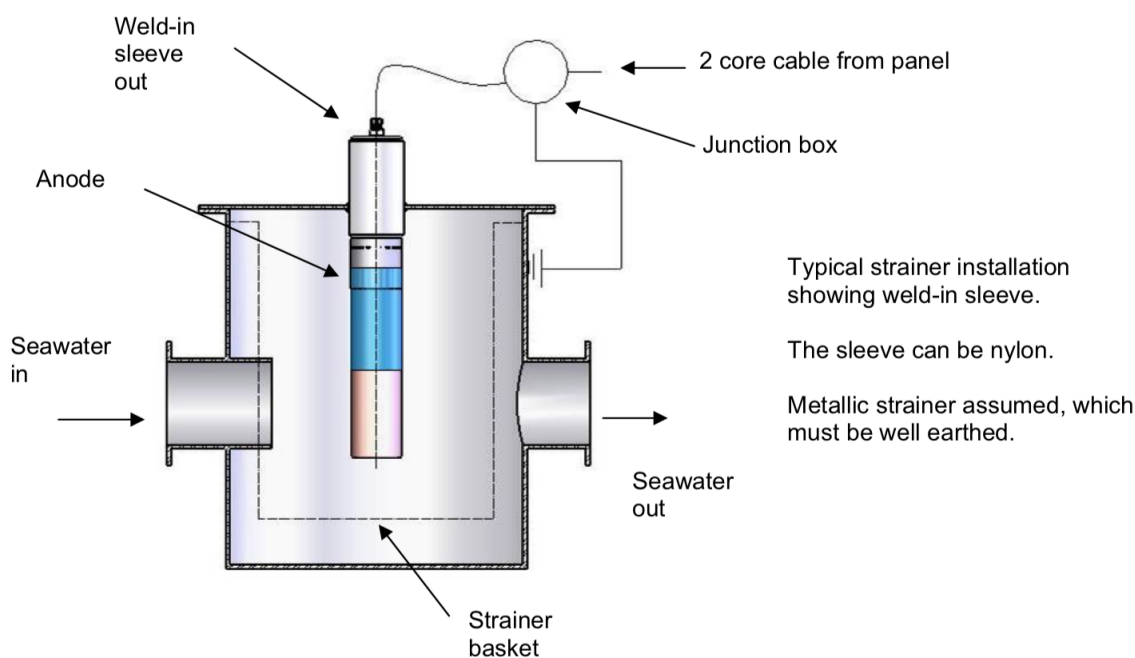

Figure 4. Schematic of a copper anode-based antifouling device.



Figure 5. Example of a pneumatic ball valve.

characteristics that at least meet the stated flow and pressure requirements. Centrifugal pumps are a suitable choice, but particular attention should be paid to priming the pump. If the pump has a high capacity, a bypass line, as described previously in section 2.2.2 (Drain Tank and Pump), can be configured. Additionally, a frequency

converter can be installed to control it. This gives the opportunity of soft starts and pump speed reduction. A soft start will draw less current when starting the pump and place less strain on the electric system. Changing pump speed will alter its performance and can be used to control the flow.

2.2.6 Tubing for Freshwater

The General Oceanics system has the capability of flushing the tubing, equilibrator, and cartridge filter if it is connected to a source of freshwater. Flushing has the dual advantage of limiting the growth of marine organisms in the parts that are flushed, as well as backflushing some particles out of the cartridge seawater filter, which then needs to be cleaned less often. Tubing (reinforced Tygon or stainless steel) is needed to connect the wet box to the freshwater intake.

2.3 Hardware Suggestions

Hardware examples listed by function that are commonly used with the General Oceanics system can be found in **Table 1**.

Table 1. Examples of hardware commonly used with the General Oceanics system.

Function	Manufacturer	Model	Link
Sea surface temperature	Sea-Bird Scientific	SBE-38	www.seabird.com
Equilibrator temperature	Fluke	1521 or 1523, with platinum resistance thermometer	us.flukecal.com
Sea surface salinity	Sea-Bird Scientific	SBE-45 microTSG	www.seabird.com
Atmospheric pressure	GE	Druck RPT350	www.gemeasurement.com
Equilibrator pressure	Setra	270 (absolute) or 239 (differential)	www.setra.com
Drain and seawater pump	MTH pumps	T41P-SS	www.mthpumps.com
Drain and seawater pump motor	Leeson Electric Corp.	½ HP motor, 1725 rpm, part no. C4C17FK5B	www.leeson.com
Air line	Synflex®	¾" to ½" Synflex 1300 metal/plastic composite tubing	
Air line intake	General Oceanics	Bow Air Intake Assembly	http://www.generaloceanics.com/bow-air-intake-ass-y-rain-guard-a900776.html
Ball valves	McMaster-Carr	Threaded on/off valve for water	https://www.mcmaster.com/#ball-valves/=168bdoj
Strut channels	McMaster-Carr	Low-profile 316 stainless steel channel	https://www.mcmaster.com/#33085t94/=168b7k6

3. Preparing for Installation

3.1 Choosing a Location for Components

3.1.1 Find a Space to Mount the System

Space is needed for the system, drain tank and pump, and the gas standards.

Things to consider

- Temperature in the space. If the temperature is too high, the electronics will not cool down and will eventually stop working. Previous experience has shown that a General Oceanics system can be run in a 30°C environment; however, key components such as the IR analyzer will fail when the temperature reaches around 40°C. A well-ventilated space can prevent the temperature from building up inside the system.
- Cleanliness of the space. The system is enclosed in boxes, but drips or dust particles will eventually find their way inside the boxes through the vents. When the boxes are opened, this may cause problems. The cleaner the space, the better.
- Access to the system. Besides accommodating the dimensions of the system, the space should have easy access to perform routine maintenance and repairs on the system.
- Vibrations from the engine can impact the system's performance and longevity. If the system is to be directly mounted to the bulkheads of the vessel, some sort of damping should be implemented to mitigate as much vibration as possible. This can be accomplished by adding rubber, or some other type of damping material, between the system and its mounting. This has the added advantage of electrically insulating the system from the ship. Not doing so can create grounding issues, as the ground on a ship is very different from the ground on land.

3.1.2 Locate Access to Seawater Source

The seawater provided to the system should:

- Be clean.
- Provide enough pressure (5-7 psi at the system) and flow (at least 4 L/min).

- Be fast flowing up to the connection of the underway system to ensure that seawater measured by the system is as representative of the surface seawater as possible.
- Have minimal bubbles.
- Come directly from the seawater intake and not be recirculated (commercial ships sometimes recirculate seawater to control engine cooling).
- Be as close to the system as possible to minimize transit time and temperature differences.

It is important to find a means to remove the seawater once analyzed (this will determine the pump). If the system is below the water line, the seawater will need to be pumped overboard. Things to consider are:

- How much back pressure will be in the pipe used to evacuate the seawater?
- Will that pipe ever be closed?
- What fail-safe mechanism will be used to stop the seawater flow to the system if the drain line or pump becomes blocked?

These factors will affect the choice of the pump used to perform the evacuation.

3.1.3 Locate Power Source and Voltage for System

The General Oceanics system requires about 650 W of power. The drain pump will also need about the same amount of power. A 15A circuit breaker should be sufficient for the entire system. The system can be run with a clean uninterrupted power supply if available but not the drain pump, which would contaminate the clean power source.³

The voltage is not as important, as most electronic components run off of their own power supplies which can usually accept either 220 VAC or 110 VAC. The voltage limits of each component should be checked, of

³Note that ships have a floating ground, and many uninterrupted power supplies (UPS) do not function appropriately and/or do not provide "clean power" under these conditions. A UPS that works with a floating ground and is appropriate for ships should be used.

course, prior to powering up the system. In particular, the LI-COR IR analyzer and pumps need to be configured to accept the correct voltage.

3.1.4 Find a Location for the Deck Box

Research vessels in general will provide sensor data such as GPS, atmospheric pressure, wind speed, ship speed, etc., as well as Internet access to transmit data. When these are not available, a deck box needs to be installed. A deck box contains sensors that need to be mounted outside the ship: a GPS transducer, a pressure transducer, and an Iridium satellite modem (or equivalent) for ship-to-shore data transmissions. If the deck box is mounted inside the ship, cables for the sensors need to be run to the outside. Besides these added complications, it is our experience that the quality of the Iridium communications will also be greatly affected, and we do not recommend this solution.

Installing a deck box requires:

- A clear view of the sky. This is primarily for the Iridium modem and for the GPS. An installation on the radar mast above the bridge has proven to work well. The presence of the radar has not been shown to affect communications.
- Power. A power outlet on an exterior upper deck of a ship is hard to come by. If power is not available, one solution is to bring the power from the underway system itself by running an extra cable along with the signal cables. When communications with the deck box fail, the deck box needs to be turned off and on. This setup allows one to do so while sitting in front of the system without having to go to the top deck.
- Cable run. This is often the hardest part of the installation. Signal cables (and sometimes power cables) need to be run from the system to the deck box. This means running cables through several decks to reach above the Bridge. The route has to be determined before installing the deck box.

3.1.5 Find a Location for Atmospheric Air Intake

An air line to sample atmospheric air has to be run to a location where contamination of the air can be minimized. As mentioned previously, the preferred location would be

at the bow of the ship, possibly raised on a mast away from the ship's structure. This is, however, not always possible. The choice of location should take into consideration the distance to the ship's stack gases and other sources of contamination like galley vents and the turbulence created by the ship's structure which could bring contaminated air into the inlet.

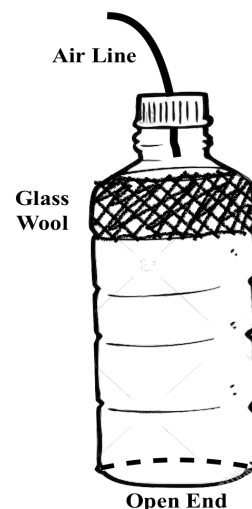

Figure 6. Example of an air line termination kit.

The air line intake should be protected from the elements as much as possible so as to limit particle and droplets from entering the line. General Oceanics sells a kit that includes a glass wool filter (<http://www.geraloceanics.com/bow-air-intake-ass-y-rain-guard-a900776.html>). Similar arrangements can also be custom made. Cutting a plastic bottle in half, possibly filling it with glass wool, and securing the air inlet to the mouth of the bottle can be a reasonable and affordable solution (see Figure 6).

3.2 Preparing the Ship and System

A few things should be completed before the system is brought on board and the installation started.

3.2.1 Ship Modifications

A ship generally needs modifications before an installation can be started to prepare the space.

3.2.1.1 Strut channels/racks. Strut channels are the preferred means to secure the system to the appropriate bulkhead or other self-supporting structure. If the installation happens on a research vessel, chances are there will be vertical strut channels already present that can be used to secure the system. Attach various lengths of struts horizontally and mount the boxes on them.

On most vessels, however, the chosen space will not have strut channels in place. Some welding of struts on

the ship's structure might be necessary or recommended for a secure installation. For a General Oceanics system, mounting the boxes on horizontal members of the frame is preferred, as it is better suited to support the weight of the heavy boxes. It will also make the mounting easier if only a limited number of hands are available to hold the unit in place while installing.

Half-height (13/16"), 316 stainless steel strut channels are suggested for the work (Figure 7). They have a lower profile and resist corrosion even in a harsh environment. Custom made steel frames can also be built that can be mounted on welded standoffs to avoid ship structures when the mounting surface does not allow for strut channels. Figure 8 shows such an installation.

3.2.1.2 Power. Power is rarely available as a standard outlet on cargo ships. Often, the engineers on board have to provide a connection to a panel and run a cable to the space where the system will be installed. This should be addressed before starting the installation. On a lot of commercial vessels it is easier to obtain three-phase power. In these cases, one has to install a strong enough transformer to get the desired voltage of 110 V or 220 V.

3.2.1.3 Water Intake and Outlet. Research vessels usually have readily available supplies of seawater and sometimes freshwater (for backflushing/cleaning). These supplies are not normally available on commercial ships. It is common

that engineers have to weld a threaded piece of pipe to an existing seawater pipe (like the pipes of the engine cooling system). This will probably also have to be done for the outlet.

It is necessary to be able to shut off the intake and outlet, so some kind of manual valve (like the ball valve pictured in Figure 9) should also be installed. Stainless steel ball valves are well suited for this task, unless the location of the intake requirements prevent this.

3.2.1.4 Freshwater Intake Valve. It is recommended that the freshwater intake have a ball valve.

3.2.2 System

3.2.2.1 Deck Box Signal and Power Cables/Air Line. A big part of the installation is running the cables to the deck box and the air line. Before the installation can begin, the path to run them must be identified and the length of required cables and tubing estimated.

The choice of path should take into consideration the following factors:

- Accessibility of the path.
- How exposed to possible damage the power cables and air line will be.
- Whether the power cables and air line will interfere with work and/or passage on the ship.

Low-Profile, Slotted Hole, 316 Stainless Steel

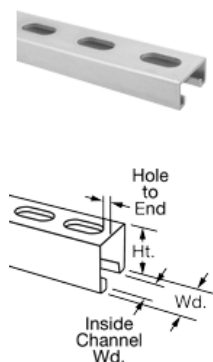

Construction	Slotted Hole
Strut Channel Type	Single
Shape	Straight
Height	13/16"
Width	1 5/8"
Thickness	0.08"
Inside Channel Width	7/8"
Hole	
Width	0.56"
Length	1.13"
Center-to-Center	2"
Hole-to-End	7/16"
Material	316 Stainless Steel
RoHS	Compliant

(<https://www.mcmaster.com/#33085t94/=168b7k6>)

Figure 7. Example of strut channel specifications.



Figure 8. General Oceanics system mounted on a custom built steel frame. As shown in the photo, the wet box is already mounted. The frame extends to the left to the mount of the dry box.

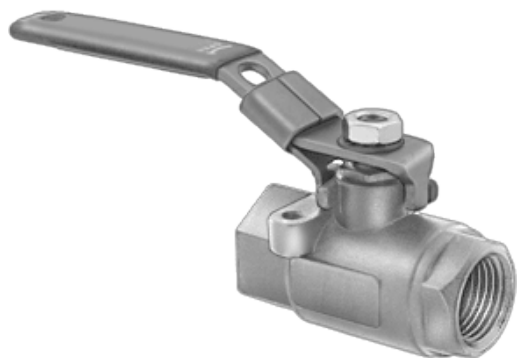

Figure 9. Illustration of a ball valve.

3.2.2.2 Drain Tank Customization for Installation. The drain tank is a bulky item, and its location is linked to that of the wet box. Since the equilibrator drains by gravity, not only does the drain tube have to be of sufficient internal diameter ($\frac{3}{4}$ " to 1") but its position also has to be such that the tubing has enough slope (taking into account the ship's movement at sea) to avoid backup and/or spillage of the drain water. There are many form factors for tanks available on the market. The choice of a suitable tank should consider:

- Where and how high the wet box can be installed to ensure good drainage.
- Whether a pump can be connected to the tank, in case a sump pump is not used.
- Whether the tank can be secured.
- Whether the water will splash out of the tank when the ship moves (a system of baffles can be designed to minimize this effect).

If a sump pump with a drain sensor is not used, a mechanism to detect the water level in the tank is needed to start and stop the pump. One of the ways to achieve this is to use small magnetic float switches on the top and bottom of the tank (**Figure 10**). Things to keep in mind when building such a mechanism are:

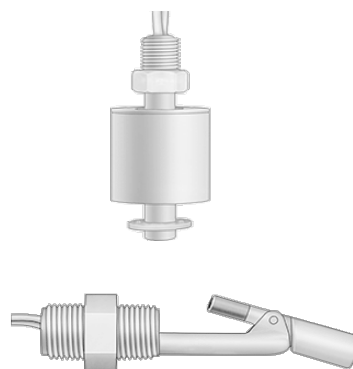

Figure 10. Illustration of a magnetic float switch.

- The tank should never be completely empty unless the pump is self priming. When a non-self priming pump loses prime, it will stop working and the tank will overflow.
- It is good practice to use two floats switched at two different locations on top of the tank to prevent the movement of the ship from affecting the detection of the full level.
- An additional level sensor (topmost sensor in **Figure 10**) should be placed higher than the full-level sensors in case they fail. It should be a trigger to shut down the system and avoid flooding the ship. In the General Oceanics system, these sensors can be connected to an analog input channel which can be used by controlling software to shut off the seawater supply.
- A piece of tubing extending from the tank outlet port to the middle of the tank's bottom (see **Figure 11**, left) will ensure that air will not be introduced into the evacuation line and prevent loss of prime.
- A tall tank (**Figure 11**, right) is preferred if vertical space is available.

Such a tank has a smaller footprint and a reduced impact of turbulence on the level sensors.

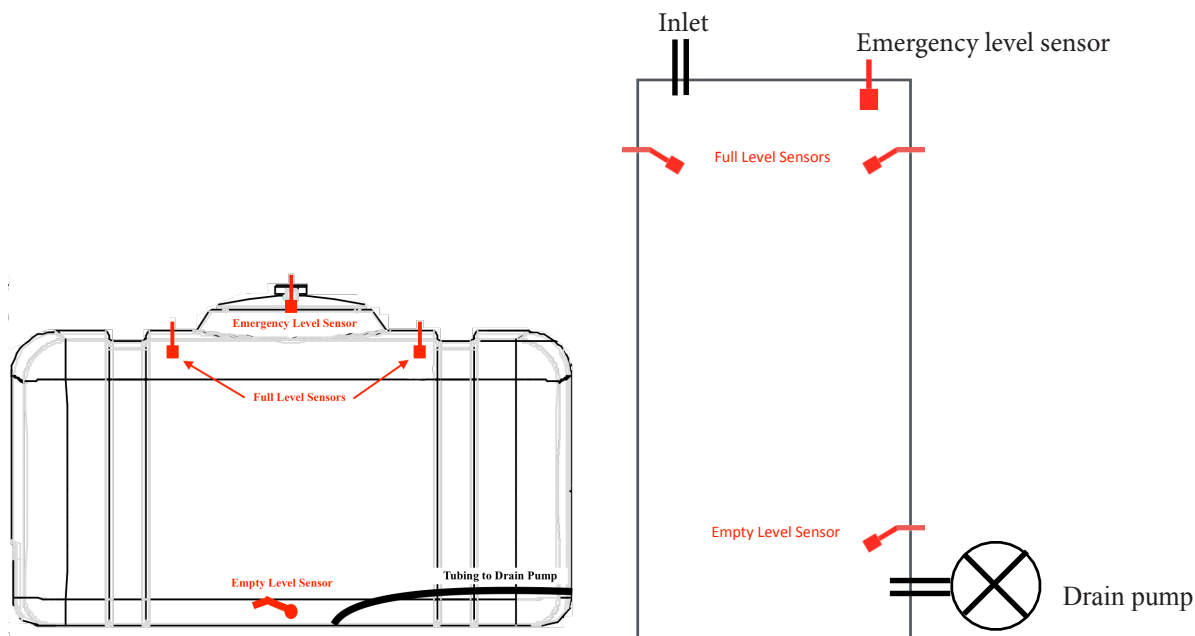

Figure 11. Setup diagram of drain tanks.

4. Installing the System

4.1 Main Components

4.1.1 System (space considerations, relative positioning of components)

When positioning the dry and wet boxes, several factors should be taken into consideration:

- Both boxes should be positioned to allow easy access.
- It is highly recommended to place the dry box with all the electronics at a higher level than the wet box, to minimize damage in case of a leak.
- The height of the dry box should be such that working on the computer is fairly comfortable, either in a standing or sitting position.
- The General Oceanics wet box needs to evacuate the hot air generated by the Peltier cooler (the “chiller”) on the right side of the box. There should be sufficient room left on the right side for air to circulate freely.
- The distance between the two boxes should be kept to a minimum to minimize the length of tubing recirculating the headspace gas. Longer tubing will increase the response time of the equilibration process.

4.1.2 Drain Tank and pump

A drain tank and pump installed on a ship are shown in Figure 12. A few things to consider include:

- The drain tank can be secured to a piece of strut channel using ratchet straps if synthetic straps are allowed by the ship.
- Some non-skid padding can be used under the tank to minimize the possibility of sliding.

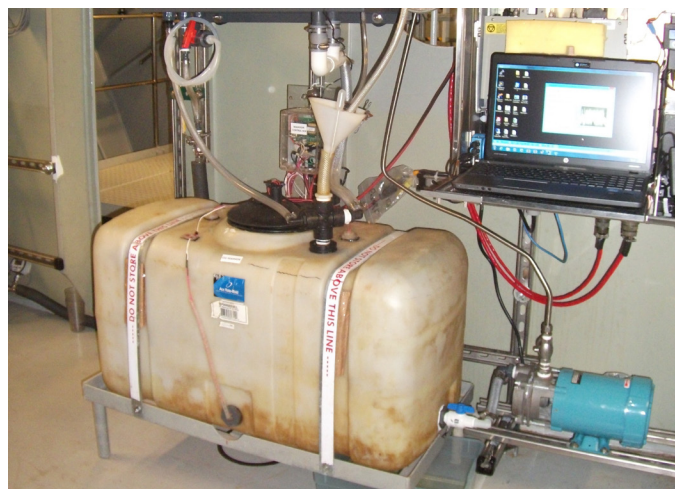

Figure 12. Drain tank and pump installed on a ship.

- The pump, if not placed inside the tank, can be mounted on a short piece of strut secured to the ship's floor or bulkhead and rest on rubber feet touching the ground to minimize the effects of vibrations when the pump is running.
- The pump should be placed at a height lower than the level of the water when the tank is full, so as to allow the pump to be primed by gravity.
- A check valve between the pump and the water outlet is recommended to prevent the already pumped water from backflushing through the pump into the tank.

Note about the drain hose: It has been observed that a long drain tube from the equilibrator can create more air entrapment in the equilibrator than the syphon break can handle (see instrument manual and section 6.3 [Miscellaneous Problems] at the end of this document). The effect of this problem is the creation of a vacuum in the equilibrator headspace which raises the seawater level in the equilibrator. This vacuum can be momentary, in which case the seawater level in the equilibrator will fluctuate up and down (possibly causing a noisy signal due to pressure fluctuations in the analyzer), or it can be permanent and lead to flooding of the equilibrator and the gas lines, at which point the system will need to be shut down and the lines rinsed and dried. If it has been determined that the syphon break inside the equilibrator is insufficient, another syphon break can be added in the drain hose by installing a tee and a vertical hose with an open end extending above the wet box (see [Figure 13](#)).

Note about pump priming: For the pump to be primed by water in the tank when full, not only does the water level in the tank need to be above the pump intake, but the water also needs to flow freely through the pump. The latter might not be possible if the pump is evacuating the water into another pipe with back pressure. If the pump loses priming, it will be difficult to prime it again. A work-around is to install a tee right after the pump with one branch of the tee going toward the exit overboard and the other branch going back into the drain tank with a ball valve to close that branch in normal operating mode ([Figure 14](#)). When opened, this should allow water to flow through the pump and prime it.

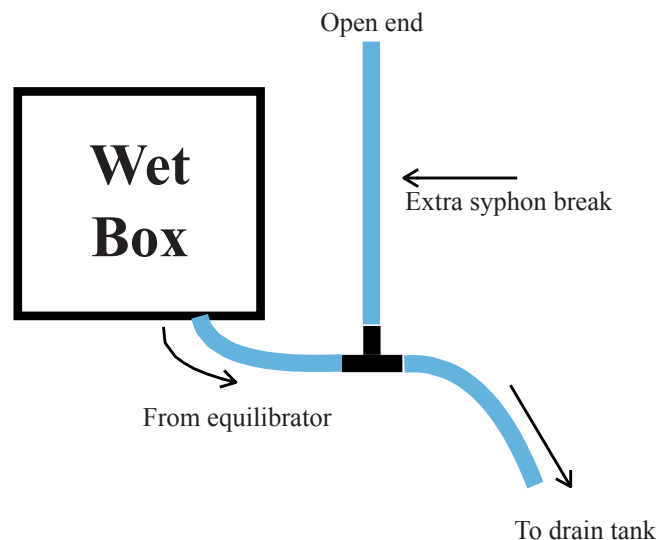

Figure 13. Extra syphon break in drain hose.

4.1.3 Seawater/Freshwater Lines and Inline Sea Surface Temperature Sensor

- Each line (seawater intake, seawater outlet, and freshwater lines) should start with some kind of valve (ball valve or other type) so that it can be closed at a moment's notice if a leak occurs anywhere in the system.
- The lines should be run without affecting ship operations and be kept away from human traffic as much as possible to avoid being damaged.
- The SST sensor should be placed as close to the seawater intake as possible or use a through-hull mounting.
- The seawater line to the underway system should be insulated as much as possible to minimize the temperature difference between the intake and the equilibrator.
- The seawater line to the underway system should have as few turns as possible to maximize the pressure and flow in the system. If the distance to the system is substantial, the inner diameter size of the tubing can be increased to provide adequate flow. The General Oceanics system is built to accept a 3/8" tubing, but it can be increased by changing the NPT-to-barb connector at the seawater intake port of the system.

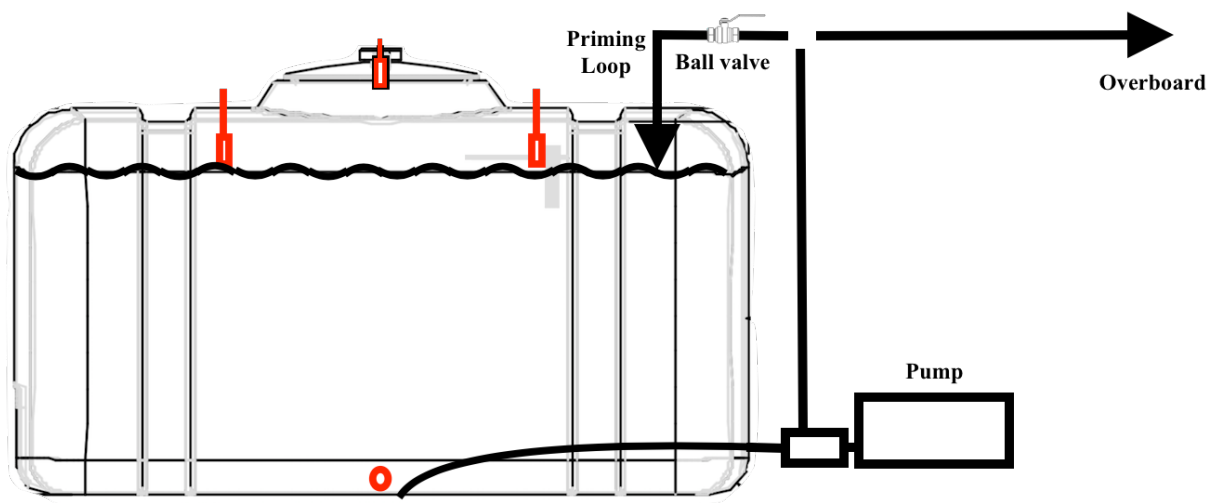

Figure 14. Drain tank setup to facilitate priming the pump.

- It is preferable to choose a slightly larger inner diameter for the seawater outlet tubing coming out of the drain pump to facilitate evacuation of the water. If the intake tubing to the wet box has a $\frac{3}{8}$ " inner diameter, a $\frac{1}{2}$ " inner diameter outlet tubing will be adequate for the pump.
- The General Oceanics system has a freshwater intake port which allows for the system to programmatically flush itself. However, in the current configuration, the seawater intake line does not get flushed with fresh water. An alternate setup can be considered where the freshwater line connects to a valve and a tee located right after the seawater intake valve. This would allow for the manual rinsing of the entire intake line and system when the ship is in port by simply closing the seawater valve and opening the freshwater valve (see [Figure 15](#)).
- The two-stage gas regulators on the cylinders should be installed such that the gauges are easily read but point away from human traffic so that the pressure settings are not inadvertently changed by bumping into the regulator valves.
- Before the gas lines from the regulators are connected to the system, the regulators should be flushed with the standards. This is done by mounting them on the tanks, opening the second stage slightly, opening the tank to pressurize the regulator and closing it right away, then letting the regulator depressurize slowly until empty. This procedure should be repeated at least four to five times to ensure that all of the

4.1.4 Standard Gas Cylinders and Connecting Tubing

- The standard (reference) gas cylinders should preferably be installed in the upright position and not rest directly on the deck surface to protect the deck and the cylinders. Plywood or rubber matting should be placed underneath the cylinders. The material a ship will allow to secure the cylinders depends on the ship. Some ships will allow ratchet straps to be used, while others will require metal brackets. In either case, the captain and/or chief engineer should be consulted.

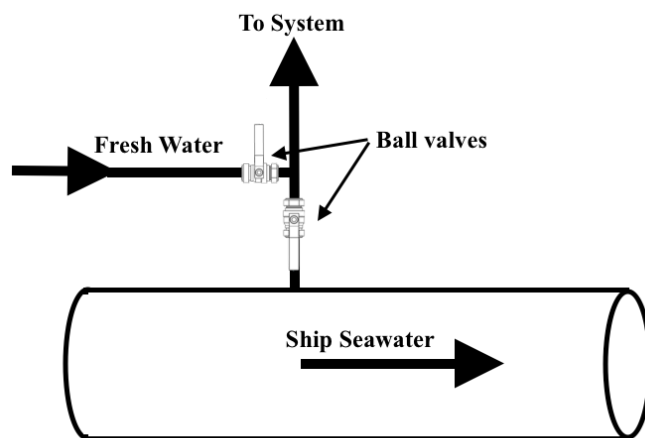

Figure 15. Best location for the freshwater supply.

internal cavities of the regulator contain only gas representative of the bulk gas standard. Not doing so will cause a drift in standards from contamination of air in the regulators and gauges which can last for days due to the low flow rates of gas standards in the standardization cycle.

- Copper tubing is preferred over stainless steel to connect the standards to the system, as it is easier to work with. However, either can be used to connect the wet box to the dry box.
- The length of the lines does not matter much, but they should be kept out of the way to prevent crimping or breaking.
- If using Swagelok[®] fittings, make sure to not over-tighten the fittings (see instructions on www.swagelok.com). Usually, a three-quarter to a one-and-a-quarter turn after finger tightening will suffice.

4.2 Peripherals

4.2.1 Air Inlet

The air inlet should be installed such that:

- The minimum amount of contamination reaches it at any time. The inlet should be as far away from the stack gases as possible and away from the ship's superstructure to avoid turbulent air that might bring contaminated air from the ship.
- It is placed slightly facing aft to avoid direct splashes or rain as the ship moves forward.
- It contains an intake filter (such as loosely packed glass wool) or coarse filter.

4.2.2. Deck Box

The deck box is not heavy so there are many options available to mount it. However, it should be kept in mind that it will be subjected to fairly harsh conditions, whether it be cold or hot temperatures, sunlight, or rain. Therefore, it is essential to ensure that the box itself and the hardware used to mount it are weather-resistant. To this effect, it is recommended to use stainless steel metal wherever possible (strut channels, U-bolts, hose clamps, etc.).

4.2.3 Cables/Air line

There are several deck box designs currently in use in the community. The General Oceanics system uses a box that includes a pressure transducer and an Iridium modem. It also has a 12V power supply and an Ethernet-to-Serial converter to connect to the sensors and the modem. In such a design, the deck box can be installed in a space inside the ship, such as the Bridge, where power can easily be found. The deck box then connects to the $p\text{CO}_2$ system via an Ethernet cable which needs to be installed. If the distance is too great, repeaters or Ethernet hubs can be used, but powering them could be an issue. The Iridium antenna, GPS transducer, and a tube for the pressure need to be run to the outside. The GPS and Iridium antenna need an unobstructed view of the sky, which could mean a long cable run. This will adversely affect data communications. Our experience has shown that data transmissions are very sensitive to cable length and position of the antenna. Communications will often fail or take a long time, thus incurring high costs.

We have had much better results using a new design that has the pressure transducer and Iridium modem inside the enclosure and the Iridium antenna and a small GPS receiver mounted just outside on the enclosure itself (see [Figure 16](#)). Category 5 (Cat 5) cables are used to connect it to the $p\text{CO}_2$ system, and successful communications have been established even over long distances. Each Cat 5 cable is made of eight conductors arranged in a twisted pair design for improved noise rejection. In this design, two extra Cat 5 cables are used to bring the power from a power supply located in the $p\text{CO}_2$ system. Two extra Cat 5 cables (for a total of four) will provide enough conductors (16) to communicate with all the components. The Iridium antenna needs nine conductors, a Druck barometer needs two conductors, and a GPS only one, not counting the grounds. Each sensor can be grounded to the power ground in the deck box, removing the need to use a connector for the ground.⁴ Another advantage of powering the deck box from the $p\text{CO}_2$ system is that one does not need to go all the way to the top of the ship to cycle the power, which is sometimes needed when electronics stop responding. Instead, it can be done from in front of the computer.

⁴See previous footnote on possible issues with floating grounds on ships that can impact this grounding method.

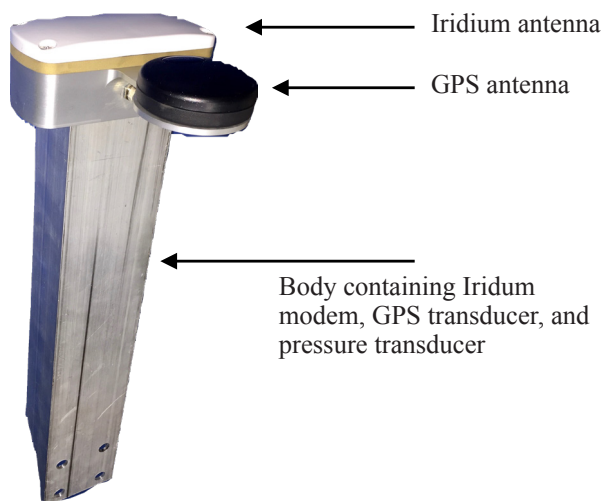

Figure 16. Example of the NOAA/AOML deck box design (contact authors for details).

It is convenient to run the four Cat 5 cables and air line at the same time, but care should be taken not to damage them when pulling them through tight spaces or around structures with sharp edges. Before running the cables, it is useful to uniquely identify and match each end of the cables with colored tape, for example, to tell which is which and connect them properly. A portion of the cables will be outdoors, so choosing ultraviolet and weather-resistant materials is highly recommended. As with anything else, these cables should be thoroughly secured and out of the way of ship operations.

5. Testing the Installation

5.1 Standard Gas Leaks

Once connected to the system, each gas standard tank should be checked for leaks. The easiest way to test for a leak is to pressurize each standard line by opening and closing the tank, and then observe if the pressure indicated by the main gauge decreases with time over a minimum of 4 hours.⁵ This test can take a while since the effects of a small leak might not be detected right away. If no appreciable change in line pressure is observed over

⁵The gas distribution valve in the dry box should not have an open port to any of the gas standards for this test.

the course of a few hours (as determined on the primary stage gauge showing a change of less than 50 psi), the line can be considered leak free.

5.2 Communication with Peripherals

One should ensure that all electrical connections are made properly and that the computer can read/control all the parts of the system. For the General Oceanics system, one needs to start the computer, go into the test panel of the General Oceanics program, and activate the pumps and valves. The values for each sensor should be checked (i.e., flows, pressures, LI-COR, etc.). One should also make certain the system is reading the GPS, Druck, and/or any other peripheral installed. The Iridium modem should be tested by sending a small text file.

5.3 System Gas Leaks

The system should be checked for leaks which can develop anywhere. The easiest way to detect a leak is to run the “set flow” utility for the equ gas in the General Oceanics program. As the equ gas is circulated in a loop from the equilibrator to the analyzer and back, the LI-COR signal displayed can be monitored as a high concentration CO₂ gas is blown into the boxes (such as human breath that contains ≈5 percent or 50,000 ppm CO₂ or a CO₂ inflator cartridge). If there is a leak, the LI-COR IR signal will rise sharply. By using a small tube to blow air into specific parts of the system, the exact location of the leak can be pinpointed and fixed.

5.4 Water Tightness of System

Once all the tubing used for the water supply has been connected, the system should be checked for water leaks by running water through the system. This is the time to set the proper water flow through the equilibrator. It should be kept in mind that the ship’s intake water pressure in port might be somewhat less than when sailing. It is a good idea to ask a crew member to check on the system after the ship leaves port and to adjust the water flow rate for at-sea conditions.

5.5 Evacuation of Seawater Drain (Water Tightness, Timing)

Concurrent with the water tightness of the system, the drainage of seawater should be checked. A few things to consider include:

- The drain pump might not work. On first use, it is not unusual for the pump to need priming.
- An estimate of how fast the drain tank fills and how fast the pump drains is needed.
- Any leak detected in this part of the manifold must be fixed.

5.6 Emergency Shutoff

An emergency shutoff mechanism should be put in place if the system is to be run unattended. The General Oceanics system can be configured to automatically shut down for different conditions, such as water detected in the gas lines or at the bottom of the wet box. It is highly recommended to install a mechanism to detect whether the drain tank is overflowing or not. These emergency shutoff mechanisms, whatever they are, should be tested fully before starting the system.

6. Potential Issues

6.1 Ground Issues on Ships

Electrical ground on a ship at sea, a so-called floating ground, is a different concept than electrical ground on land and can cause issues with electronics and their signals. To minimize these problems, it is recommended to avoid electrical contact between the system and the ship by inserting some sort of rubber feet or dampeners on the strut channels holding the system. This will also help minimize vibrations in the dry box. The use of three-phase power can also help with the ground issue.

6.2 Recirculating Seawater

A ship generally uses very powerful pumps and big pipes to circulate seawater as a coolant for their engines. This seawater is taken from a sea chest at a very high flow, which

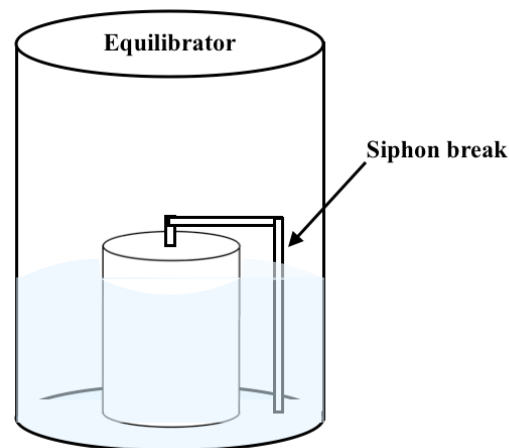

Figure 17. Illustration of a siphon break.

makes it a good intake for an underway $p\text{CO}_2$ system. The water is normally dumped back into the ocean away from the intake sea chest, therefore not affecting the intake water. Some ships (usually cargo ships) recirculate this water to better control engine temperature. As the water cools the engine, it gets warmer. When it is recirculated, the temperature signature of the water shows a larger spread than usual. When this happens, the intake water is no longer representative of the surface water, making the $p\text{CO}_2$ measurements meaningless. There are no easy solutions to this problem except perhaps talking with the engineers and asking them to limit the recirculating time as much as possible. If recirculation happens too often, finding an alternate source of water, or even a different vessel, should be considered.

6.3 Miscellaneous Problems

Water comes out of the syphon break of either or both equilibrators (Figure 17). This should not happen. However, it does occur on some installations, mostly when the seas are rough. The solution is to connect the syphon break outlet via a small tube to either the drain tank or a small container. Make certain the tube and/or container is also open to the atmosphere. The amount of water splashing out of the syphon breaks is minor so a small container should suffice.

7. References

- Bender, M., Doney, S.C., Feely, R.A., Fung, I., Gruber, N., Harrison, D.E., Keeling, R., Moore, J.K., Sarmiento, J., Sarachik, E.S., Stephens, B., Takahashi, T., Tans, P., and Wanninkhof, R., 2002: A large-scale CO_2 observing plan: In situ oceans and atmosphere (LSCOP). NOAA OAR Special Report/NOAA Office of Global Programs, Washington, DC, 201 pp.
- Juranek, L.W., Hamme, R.C., Kaiser, J., Wanninkhof, R., and Quay, P. D., 2010: Evidence of O_2 consumption in underway seawater lines: Implications for air-sea O_2 and CO_2 fluxes. *Geophysical Research Letters*, 37:L01601, doi:10.1029/2009GL040423.
- Pierrot, D., Neill, C., Sullivan, K., Castle, R., Wanninkhof, R., Luger, H., Johannessen, T., Olsen, A., Feely, R.A., and Cosca, C.E., 2010: Recommendations for autonomous underway $p\text{CO}_2$ measuring systems and data-reduction routines. *Deep-Sea Research, Part II*, 56:512-522, doi:10.1016/j.dsr2.2008.12.005.
- Wanninkhof, R., Bakker, D.C.E., Bates, N., Olsen, A., Steinhoff, T., and Sutton, A.J., 2014: Incorporation of alternative sensors in the SOCAT database and adjustments to dataset quality control flags. Carbon Dioxide Information Analysis Center, Oak Ridge National Laboratory, US Department of Energy, Oak Ridge, TN, doi:10.3334/CDIAC/OTG.SOCAT_ADQCF, 26 pp.



National Oceanic and Atmospheric Administration

OFFICE OF OCEANIC AND ATMOSPHERIC RESEARCH
Atlantic Oceanographic and Meteorological Laboratory

4301 Rickenbacker Causeway
Miami, FL 33149

www.aoml.noaa.gov